

Performance Curve - BL(T)2

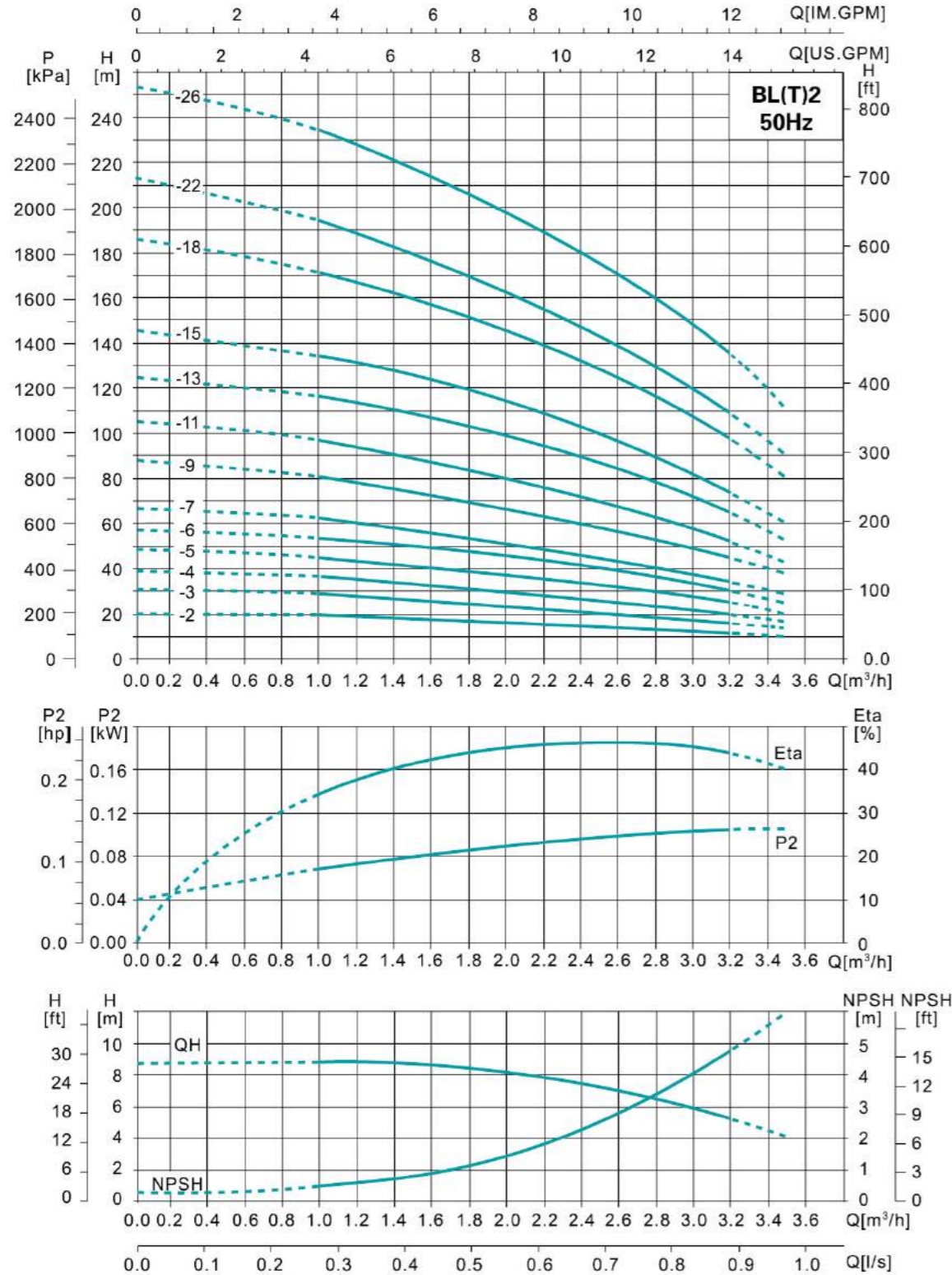

It is recommended to be used within lift range.

Performance Table

Model	Power		Q (m³/h)	1	1.2	1.6	2	2.4	2.8	3.2	Head Range (m)
	kW	HP		H (m)							
BL(T)2-2	0.37	0.5	H (m)	18	17	16	15	13	12	10	10~18
BL(T)2-3	0.37	0.5		27	26	24	22	20	18	15	15~27
BL(T)2-4	0.55	0.75		36	35	33	30	26	24	20	20~36
BL(T)2-5	0.55	0.75		45	43	40	37	33	30	24	24~45
BL(T)2-6	0.75	1		53	52	50	45	40	36	30	30~53
BL(T)2-7	0.75	1		63	61	57	52	47	41	35	35~63
BL(T)2-9	1.1	1.5		80	78	73	67	61	54	45	45~80
BL(T)2-11	1.1	1.5		98	95	89	82	73	64	54	54~98
BL(T)2-13	1.5	2		116	114	106	98	89	78	65	65~116
BL(T)2-15	1.5	2		134	130	123	112	100	90	73	73~134
BL(T)2-18	2.2	3		161	157	148	136	121	108	91	91~161
BL(T)2-22	2.2	3		197	192	180	165	148	130	110	110~197
BL(T)2-26	3	4		232	228	214	198	179	158	130	130~232

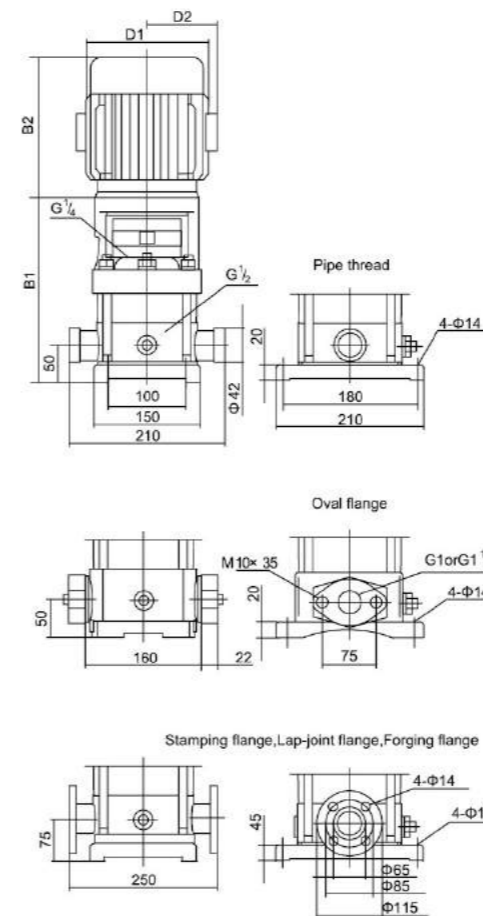

Dimensions & Weight

Model	Dim.(mm)					N.W.(kg)
	B1	B2	B1+B2	D1	D2	
BL(T)2-2	278	220	498	135	86	22/26
BL(T)2-3	278	220	498	135	86	22/26
BL(T)2-4	296	220	516	135	86	24/28
BL(T)2-5	314	220	534	135	86	24/28
BL(T)2-6	340	255	595	148	96	28/32
BL(T)2-7	358	255	613	148	96	28/32
BL(T)2-9	394	255	649	148	96	31/35
BL(T)2-11	430	255	685	148	96	32/36
BL(T)2-13	479	300	779	166	115	35/40
BL(T)2-15	515	300	815	166	115	36/40
BL(T)2-18	569	300	869	166	115	40/45
BL(T)2-22	641	300	941	166	115	42/46
BL(T)2-26	722	325	1047	191	128	50/55