

Performance Curve - BL(T)45

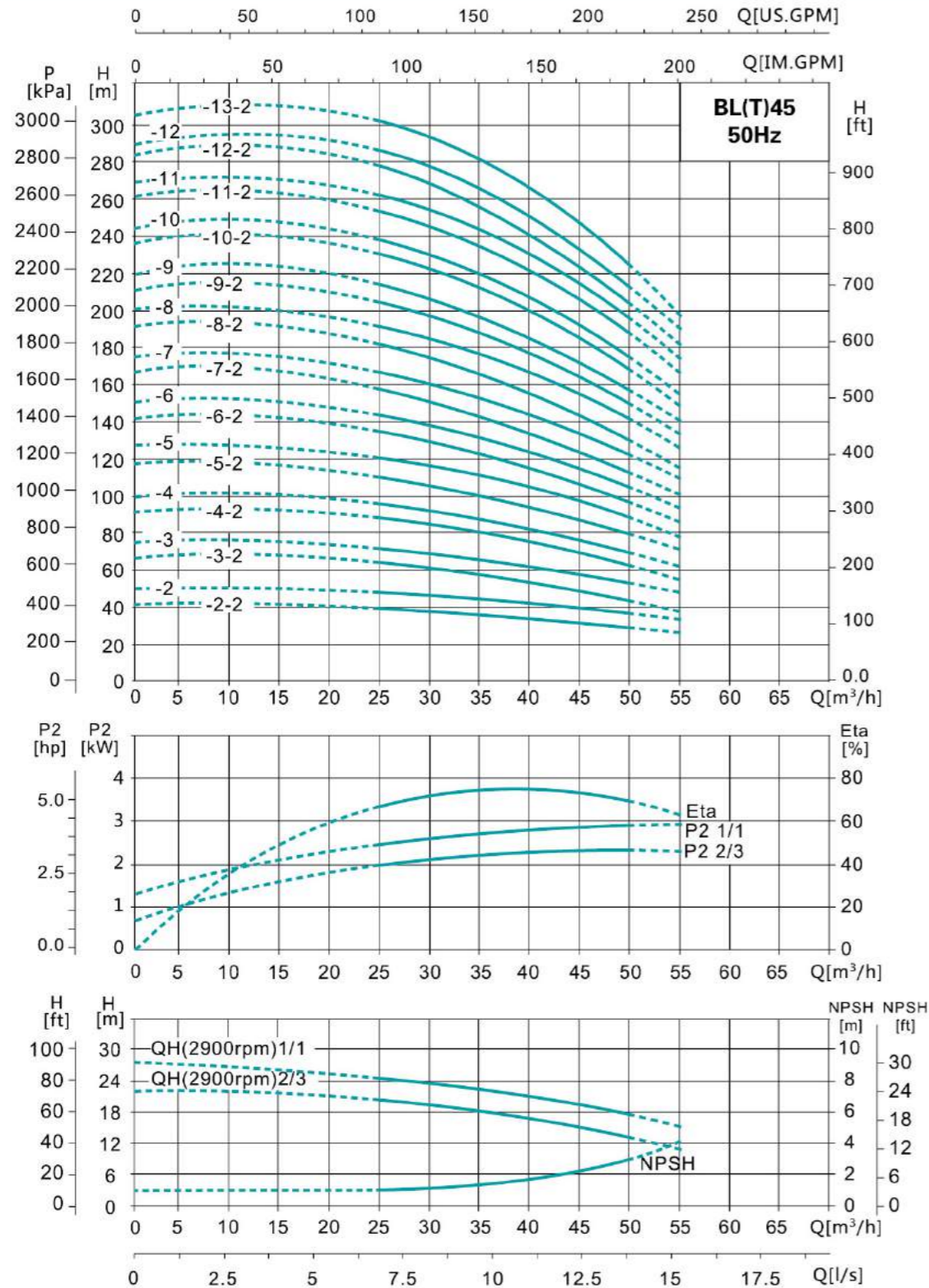

It is recommended to be used within lift range.

Performance Table

Model	Power		Q (m³/h)	25	30	35	40	45	50	Head Range (m)
	kW	HP		H (m)						
BL(T)45-2-2	5.5	7.5	40	38	36	33	30	27	27~40	
BL(T)45-2	7.5	10	48	46	44	42	39	35	35~48	
BL(T)45-3-2	11	15	63	61	58	54	50	44	44~63	
BL(T)45-3	11	15	71	69	66	63	58	53	53~71	
BL(T)45-4-2	15	20	87	84	80	75	69	62	62~87	
BL(T)45-4	15	20	95	92	88	84	78	71	71~95	
BL(T)45-5-2	18.5	25	111	107	102	96	88	80	80~111	
BL(T)45-5	18.5	25	119	115	110	105	97	88	88~119	
BL(T)45-6-2	22	30	135	130	124	117	108	97	97~135	
BL(T)45-6	22	30	143	138	132	125	116	106	106~143	
BL(T)45-7-2	30	40	158	152	146	138	127	115	115~158	
BL(T)45-7	30	40	166	161	154	146	135	124	124~166	
BL(T)45-8-2	30	40	182	175	168	159	146	133	133~182	
BL(T)45-8	30	40	190	184	176	167	159	141	141~190	
BL(T)45-9-2	30	40	205	198	190	180	166	150	150~205	
BL(T)45-9	37	50	214	207	198	188	174	159	159~214	
BL(T)45-10-2	37	50	230	221	212	200	185	168	168~230	
BL(T)45-10	37	50	238	230	220	209	193	177	177~238	
BL(T)45-11-2	45	60	255	246	236	223	206	188	188~255	
BL(T)45-11	45	60	263	255	244	232	214	196	196~263	
BL(T)45-12-2	45	60	280	270	259	245	226	206	206~280	
BL(T)45-12	45	60	289	280	268	255	236	216	216~289	
BL(T)45-13-2	45	60	305	294	282	267	247	225	225~305	

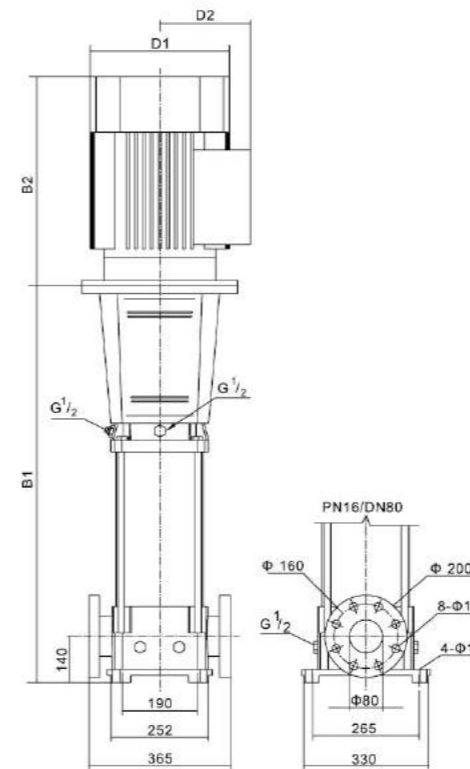

Dimensions & Weight

Model	Dim.(mm)					N.W.(kg)
	B1	B2	B1+B2	D1	D2	
BL(T)45-2-2	716	395	1111	258	163	109/117
BL(T)45-2	716	395	1111	258	163	113/121
BL(T)45-3-2	826	498	1324	315	251	190/197
BL(T)45-3	826	498	1324	315	251	190/197
BL(T)45-4-2	906	498	1404	315	251	204/211
BL(T)45-4	906	498	1404	315	251	204/211
BL(T)45-5-2	986	542	1528	315	251	225/233
BL(T)45-5	986	542	1528	315	251	225/233
BL(T)45-6-2	1066	578	1644	355	267	272/279
BL(T)45-6	1066	578	1644	355	267	272/279
BL(T)45-7-2	1146	669	1815	397	299	351/359
BL(T)45-7	1146	669	1815	397	299	354/361
BL(T)45-8-2	1226	669	1895	397	299	351/359
BL(T)45-8	1226	669	1895	397	299	354/361
BL(T)45-9-2	1306	669	1975	397	299	380/388
BL(T)45-9	1386	669	2055	397	299	358/366
BL(T)45-10-2	1386	669	2055	397	299	385/392
BL(T)45-10	1466	669	2135	446	299	385/392
BL(T)45-11-2	1466	709	2175	446	322	450/457
BL(T)45-11	1546	709	2255	446	322	450/457
BL(T)45-12-2	1546	709	2255	446	322	454/462
BL(T)45-12	1626	709	2335	446	322	454/462
BL(T)45-13-2	1626	709	2335	446	322	458/465